



Trocar Swabs

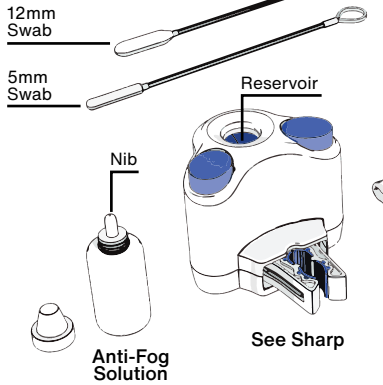

FIGURE 1

INSTRUCTIONS FOR USE

Products:

- #30977 - 100mm tocars CE 0459
- #30978 - 150mm trocars



FIGURE 2

Slide switch to activate unit

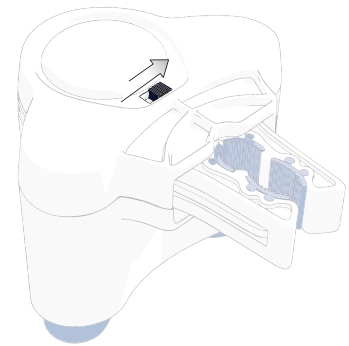

BEFORE USING PRODUCT, READ THE FOLLOWING INFORMATION THOROUGHLY.

DESCRIPTION

The Scope Antifogging System is a single use, sterile device that is designed to apply an antifogging solution and warm the scope at or above body temperature when used prior to and during procedures that utilize an endoscope or laparoscope. Included with the system is the warming hub, two bottles of antifog solution, two trocar wipes, and a microfiber cloth. The device is battery operated using two lithium batteries. Optimal operating environment is temperature between 5°C to 40 °C and relative humidity of 15% to 95%.

FIGURE 3

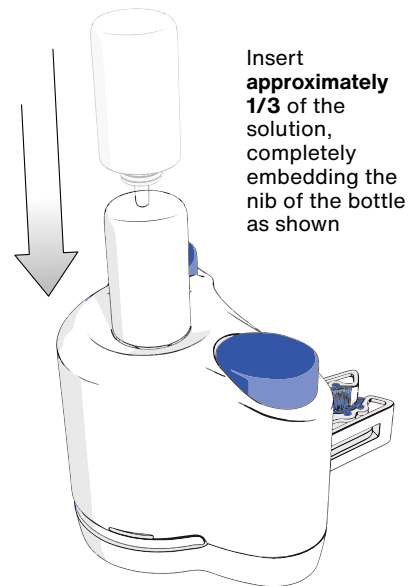

Insert approximately 1/3 of the solution, completely embedding the nib of the bottle as shown

INDICATIONS

The Scope Anti-fogging System is a single use, sterile device to be used prior to and during endoscopic and laparoscopic procedures to prevent fogging of the scope lens.

INTENDED PURPOSE AND USER

This device is intended for use by trained healthcare professionals only

CONTRADICTIONS

This device is not designed, sold, or intended for use except as indicated

KNOWLEDGE AND USE

Device is to be used by prescription only. Professional use requires knowledge of this instructions for use. Device use limited to surgical operating room in a hospital or surgery center.

CLINICAL BENEFITS

Provides a clean field & vision for professionals during surgical procedures.

FIGURE 4

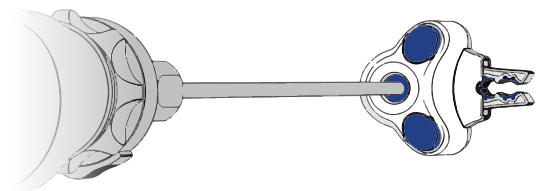

See Sharp in warming configuration on back table

PREPARATION AND USE

1. Peel the label from the package and remove the contents (*figure 1*) which include: one (1) See Sharp™ unit, one (1) microfiber cloth, one (1) 5mm trocar swab, one (1) 12mm trocar swab, one (1) bottle of anti-fog solution.
2. Invert the See Sharp unit and activate the switch (*figure 2*) on the underside of See Sharp. The unit will emit a blue light indicating a “powered on” status which will last up to 5 hours.

PREPARATION AND USE (Continued)

3. Place the See Sharp unit on a level surface.
4. Remove the lid from the anti-fog solution bottle.
5. Completely insert the open nib of the anti-fog solution bottle into the reservoir opening of the See Sharp unit. (figure 3)
6. Red lines are shown to indicate **1/3** increments of the solution. Squeeze the sides of the anti-fog solution bottle, dispensing approximately **one-third (1/3)** of the solution into the reservoir (**first red line**) and save the remaining fluid for a refill.
7. Allow five (5) minutes for See Sharp to reach optimal temperature.
8. Once the unit is warmed, insert the lens of the laparoscope into the opening of the See Sharp reservoir to the full depth of the reservoir to initiate scope warming. Note that the See Sharp may be placed on its side to facilitate scope warming on the back table (figure 4). Allow five (5) minutes to complete initial laparoscope warming.

NOTE: To diminish fogging risk, limit the duration of laparoscope exposure to open OR environment.

TROCAR ATTACHMENT

1. Upon completing the warming phase, remove laparoscope from the See Sharp and wipe away any residual cleaning/defogging solution with the included microfiber cloth.
2. Identify the connection diameter on the See Sharp's universal attachment clip appropriate for your trocar — the outer opening is for 9-12mm trocars, the inner opening is for 5-8mm trocars. (figure 5)
3. Position the See Sharp so that the universal clip is facing the trocar.
 - Align the universal attachment clip over the trocar, ensuring the clip is centered and facing the trocar shaft. (figure 6)
4. Gently apply inward pressure until the See Sharp snaps onto the trocar shaft
 - The See Sharp will snap into place on the shaft of the trocar. You may adjust the vertical position of the See Sharp on the trocar as needed. Assure that the See Sharp is as close as possible to the top of the trocar.
5. The See Sharp is now ready for use.

LAPAROSCOPE CLEANING & DEFOGGING

Follow these steps to restore optimal visibility to a fogged or soiled laparoscope.

1. Remove the laparoscope from the trocar and wipe away any heavy surgical debris with the included microfiber cloth.
2. Gently insert the tip of the laparoscope into the See Sharp to the full depth of the reservoir. The bottom of the reservoir is lined with a scratch-free double layer of sponge to cushion and protect the lens of the laparoscope.
3. Agitate the laparoscope with a rotary motion within the reservoir of the See Sharp. (figure 7)
4. Remove the laparoscope and tap the tip lightly on one of the sponges located atop the See Sharp to dissipate any excess cleaning solution.
5. Use the appropriately-sized (5 or 12 mm) trocar swab to remove any debris from within the shaft of the trocar by inserting the sponge into the trocar and swabbing in and out to ensure clean laparoscope reintroduction.

FIGURE 5

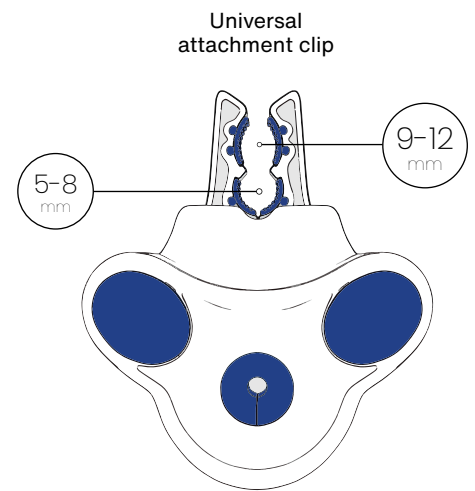

FIGURE 6

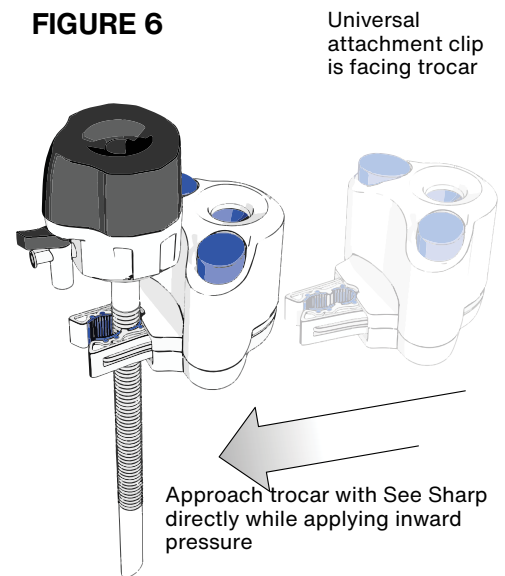
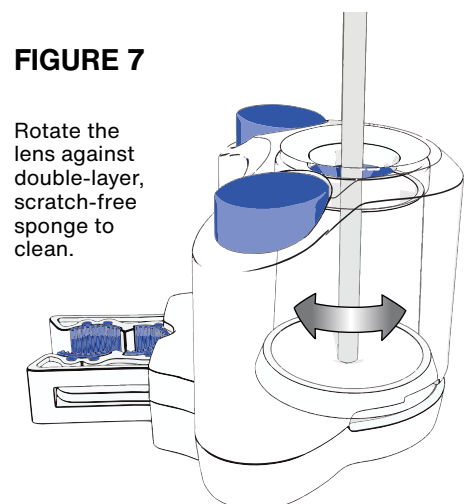

FIGURE 7



DISPOSAL

- The See Sharp may be discarded with the single use trocar. On reusable devices, simply slide See Sharp off the end of the trocar



WARNINGS

- This device was designed, test and manufactured for single patient use only. Reuse or reprocessing of this device may lead to its failure or subsequent injury
- Reprocessing and/or reesterilization of this device may create the risk of contamination and patient infection
- Do not reuse, reprocess or reesterilization this device
- After use, the See Sharp should be disposed of in accordance with local guidelines for medical waste that includes batteries
- Product complies to IEC 60601-1-2 Electromagnetic Disturbances - Device has not been evaluated against other equipment used in surgical setting
- The See Sharp should be stored in a clean, dry location at room temperature prior to use. Avoid prolonged exposure to elevated temperatures
- Please visually inspect for breaches of packaging integrity prior to use
- Do not use if damaged, opened, or breached as sterility cannot be guaranteed
- US Federal law restricts this device to sale by or on the order by a physician

PRECAUTIONS

- This product should be used in accordance with the instructions for use and any contraindications, warnings or precautions provided by the manufacturer of the associated instrument
- Notice to the User and/or patient that any serious incident that has occurred in relation to the device should be reported and the competent authority of the Member State in which the user and/or patient is established, as well as, Xodus Medical and its Authorized Representative

TECHNICAL SPECIFICATIONS

- Battery operated device - Protection against electric shock - Internally powered
- Classification of applied part - No applied parts
- Mode of operation - Continuous
- Not intended for use with flammable anesthetics or in conjunction with flammable agents
- Ingress protection - IPX0 (ordinary equipment)
- Product complies to IEC 60601-1-2 Electromagnetic Disturbances - Device has not been evaluated against other equipment used in surgical setting
- Finished product sterilized by gamma radiation
- Shelf-life — 2 years

STORAGE, TRANSPORT, AND OPERATIONAL CONDITIONS

- Scope Antifogging System should be stored in a clean, dry location at room temperature prior to use. Avoid prolonged exposure to elevated temperatures



Do Not Re-use



Use-by Date

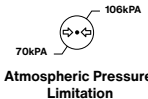

Atmospheric Pressure Limitation

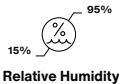

Relative Humidity



Rx ONLY Prescription Use Only



Medical Device



Not Made with Natural Rubber Latex



Consult instructions for use or consult electronic instructions for use



Do Not Use If The Package Is Damaged Or Opened



Proper Disposal Required



Operating Temperature



Caution, Consult Accompanying Documents

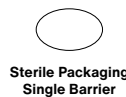

Sterile Packaging Single Barrier



Do Not Resterilize

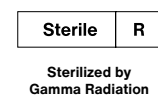

Sterilized by Gamma Radiation



Emergo Europe Westervoortsedijk 60 6827 AT Arnhem The Netherlands



702 Prominence Drive
New Kensington, PA 15068,
United States

xodusmedical.com
info@xodusmedical.com
Tel: 1+724-337-5500

FDA-REGISTRIERT
ISO 13485-ZERTIFIZIERT



LITIFUSA001 R20 6/18/2024